

CEL•LINE[®] AIR DISTRIBUTION

DIRECTIONAL SECURITY DIFFUSER

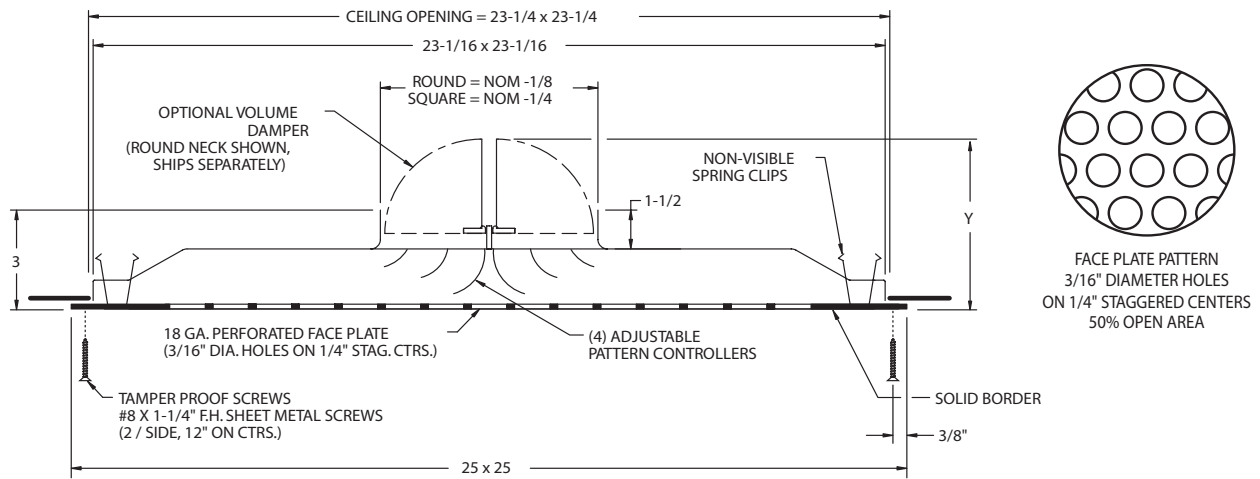

PFD-MS DIFFUSER



IMPORTANT: It is the specifier's responsibility to properly configure the HVAC system to meet the appropriate level of comfort, safety, security and detention

PRODUCT FEATURES

Face Plate

- 18 GA. (standard)
- 16 GA. (optional)

Face Plate Patterns

- 3/16" dia. holes on 1/4" stag. ctrs. (std.)
- 1/4" dia. holes on 3/8" stag. ctrs. (opt.)
- 5/16" dia. holes on 7/16" stag. ctrs. (opt.)

Material

- Cold Rolled Steel (standard)
- *Stainless Steel (optional)
- *Aluminum (optional)
- *Galvanized (optional)
- Other _____

*consult factory for availability

**Opposed Blade Damper -(optional)
(Square Neck)**

- Front Operated
- Rear Operated
- Other _____

**Butterfly Volume Damper -(optional)
(Round Neck)**

- Front Operated
- Other _____

Directional Air Pattern

- 4-way (standard)
- 1-way (optional)
- 2-way (optional)
- 3-way (optional)

Finish

- White Powder Coat (standard)
- Other _____

Other Options (please specify)

QUANTITY										
Round Neck	NOMINAL NECK DIAMETER	6ø	7ø	8ø	9ø	10ø	12ø	14ø	16ø	18ø
OPTIONAL DAMPER	Y DIMENSION	4-1/2	5	5-1/2	6	6-1/2	7-1/2	8-1/2	9-1/2	10-1/2

QUANTITY										
Square Neck	NOMINAL NECK SIZE	6x6	-	8x8	-	10x10	12x12	14x14	16x16	18x18
OPTIONAL OBD	Y DIMENSION	5-3/8								

All dimensions are in inches.



CEL•LINE[®] AIR DISTRIBUTION

SECURITY RETURN



3RPF-D-MS RETURN

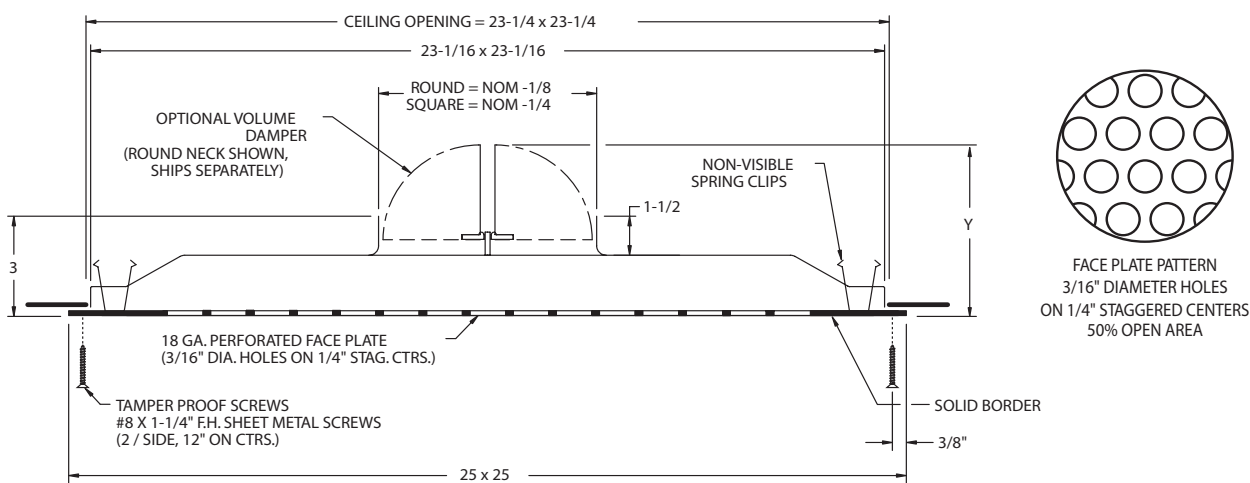

IMPORTANT: It is the specifier's responsibility to properly configure the HVAC system to meet the appropriate level of comfort, safety, security and detention

PRODUCT FEATURES

Face Plate

- 18 GA. (standard)
- 16 GA. (optional)

Face Plate Patterns

- 3/16" dia. holes on 1/4" stag. ctrs. (std.)
- 1/4" dia. holes on 3/8" stag. ctrs. (opt.)
- 5/16" dia. holes on 7/16" stag. ctrs. (opt.)

Material

- Cold Rolled Steel (standard)
- *Stainless Steel (optional)
- *Aluminum (optional)
- *Galvanized (optional)
- Other _____

*consult factory for availability

Opposed Blade Damper - (optional)
(Square Neck)

- Front Operated
- Rear Operated
- Other _____

Butterfly Volume Damper - (optional)
(Round Neck)

- Front Operated
- Other _____

Finish

- White Powder Coat (standard)
- Other _____

Other Options (please specify)

QUANTITY										
Round Neck	NOMINAL NECK DIAMETER	6ø	7ø	8ø	9ø	10ø	12ø	14ø	16ø	18ø
OPTIONAL DAMPER	Y DIMENSION	4-1/2	5	5-1/2	6	6-1/2	7-1/2	8-1/2	9-1/2	10-1/2
QUANTITY										
Square Neck	NOMINAL NECK SIZE	6x6	-	8x	-	10x10	12x12	14x14	16x16	18x18
OPTIONAL OBD	Y DIMENSION	5-3/8								

All dimensions are in inches.

